

## F1 – Double stem packing on top of stem extension

- ✓ Z **double** stem packing design on top of stem extension to avoid in general terms any possible influence of working temperature.
- ✓ Double packing increasing safety level, consider as technical solution for Hydrogen (H<sub>2</sub>) service due to its volatility.
- ✓ One piece stem, stronger design and no jamming metal to metal.
- ✓ XM-19 material as standard with improved mechanical properties than another with lower values.
- ✓ Bearing and gasket on lower side of stem
- ✓ Possible to be used for another services and upon request.

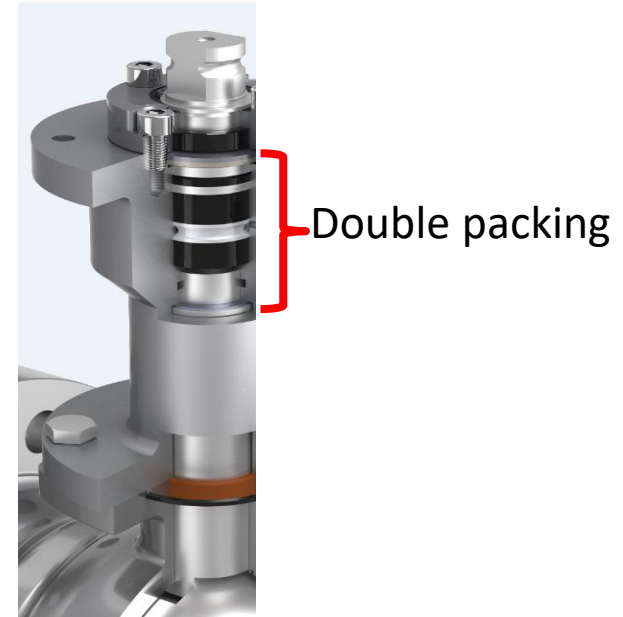

Hydrogen blasts chemical plant Japan 2014

Source: *The Week online (UK)*

## Double packing system

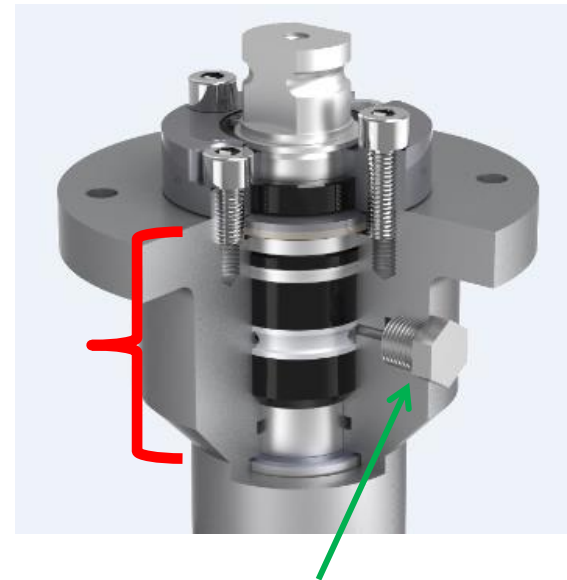
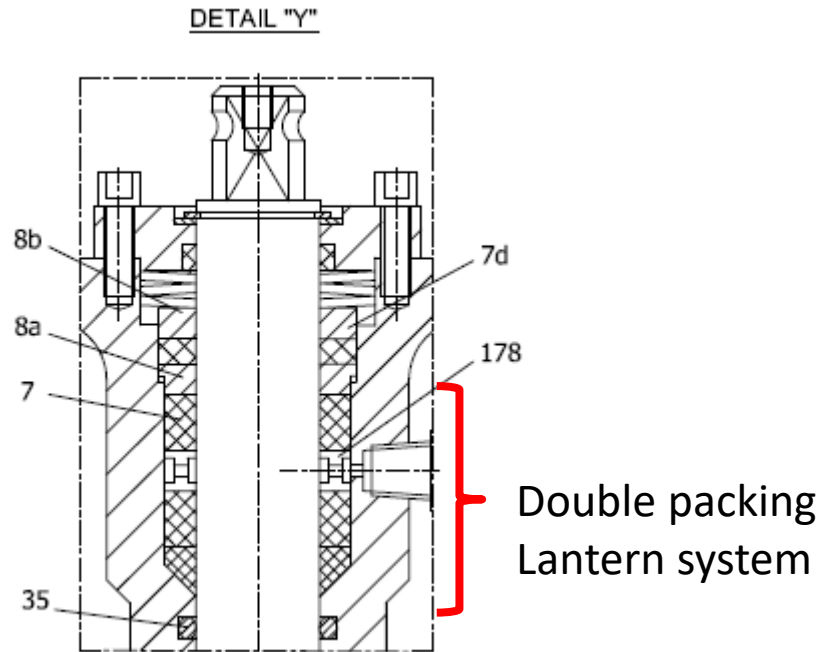

Plug as standard  
(upon request not include it)

- Possible to assemble a gause, Grease injector or another upon request.